

THIS DRAWING IS UNPUBLISHED. RELEASED FOR PUBLICATION
 © COPYRIGHT BY TYCO ELECTRONICS CORPORATION. ALL RIGHTS RESERVED.

LOC FT	DIST 0	REVISIONS			
P	LTR	DESCRIPTION	DATE	DWN	APVD
	A2	REVISED PER ECO-08-008028	01APR08	HMR	CR

MATERIALS:
 HOUSING: PA66, UL94V-0, COLOR: GREEN.
 TERMINAL: BRASS, TIN PLATED.
 CAGE CLAMP: STEEL, TRI-CHROMATE.
 SCREW: STEEL, TRI-CHROMATE.

ELECTRICAL:
 CURRENT RATING: 125A
 VOLTAGE RATING: 600V.
 INSULATION WITHSTANDS: AC2000V MIN
 INSULATION RESISTANCE: 2000Mohm/DC500V
 WIRE RANGE: 1-20 AWG

MECHANICAL:
 SCREW TORQUE: 30 IN-LB
 OPERATING TEMP.: -40° TO +105°C
 WIRE STRIP LENGTH: 18mm

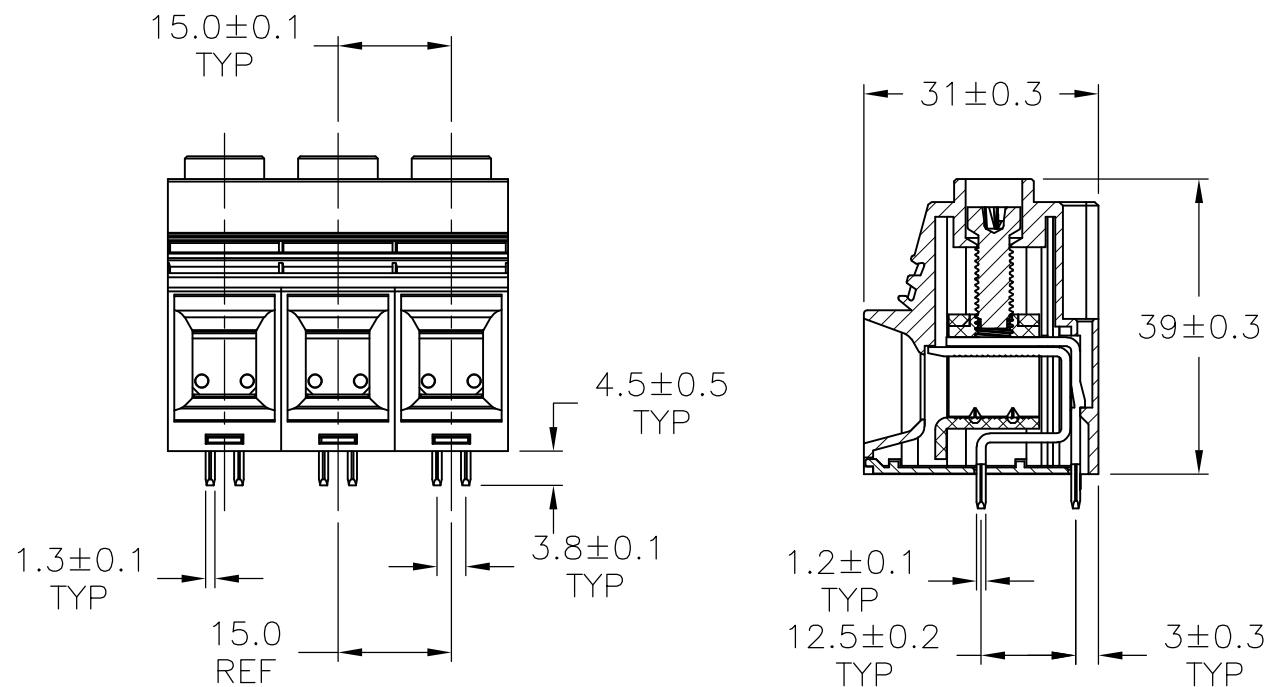
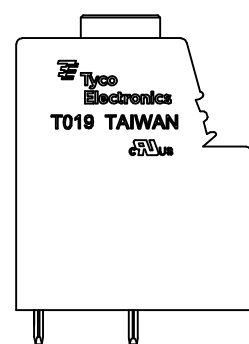
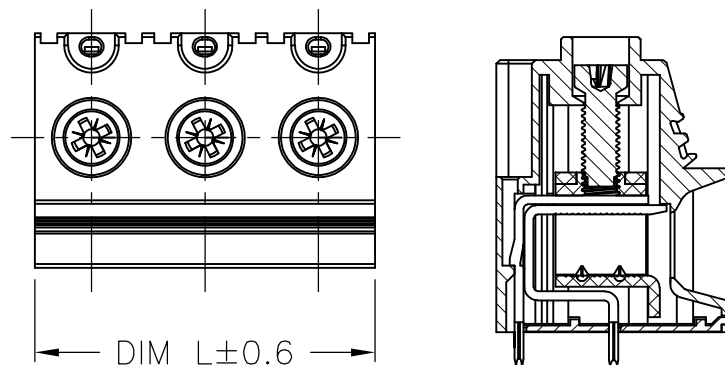

120.00	8	1986242-8
105.00	7	1986242-7
90.00	6	1986242-6
75.00	5	1986242-5
60.00	4	1986242-4
45.00	3	1986242-3
30.00	2	1986242-2
DIM L	NO OF POS	PART NUMBER

THIS DRAWING IS A CONTROLLED DOCUMENT.		DWN S SCHLEGEL 28AUG2007	Tyco Electronics Corporation Harrisburg, PA 17105-3608		
DIMENSIONS: mm		CHK C RICHARD 8/28/07			
TOLERANCES UNLESS OTHERWISE SPECIFIED:		APVD C RICHARD 8/28/07	NAME POWER CONNECTOR 15.0mm PITCH		
0 PLC ± - 1 PLC ± - 2 PLC ± - 3 PLC ± - 4 PLC ± - ANGLES ± 1°		PRODUCT SPEC -	RESTRICTED TO -		
MATERIAL -		FINISH -	APPLICATION SPEC -	SIZE A3	CAGE CODE 00779
CUSTOMER DRAWING			DRAWING NO G-1986242	SCALE 1:1	SHEET 1 OF 1
			WEIGHT -	REV A2	